

WASHR 1pcs

NUT 1pcs

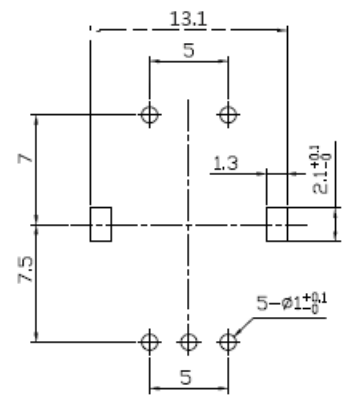

P. C. B. MOUNTING DETAIL

- 表示重点管控尺寸
- Key control dimensions

惠州市弘旺电子有限公司 HUIZHOU HOWANG ELECTRONICS CO., LTD		
MTL	SPEC	DISPOSAL
△5		UNIT MM
△4		SCALE 2 / 1
△3		TITLE: DB-EC11 Series
△2		DRAWN DESIGN CHECK APPROVAL
△1		谭超 李弘 张琪
DEVISION	DATE	DESIGN
		DWG NO.: F-EC11-01-26