

● 表示重点管控尺寸
● Key control dimensions

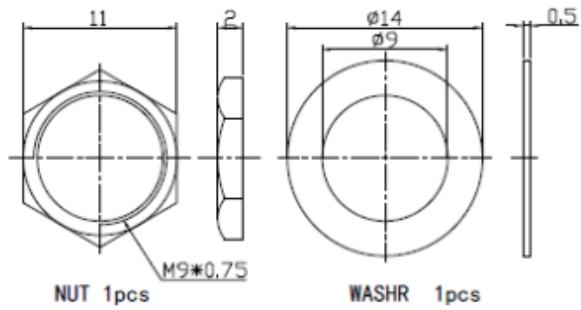

| | | |
|--|-------------|--------------------------|
| 惠州市弘旺电子有限公司 HUIZHOU HOWANG ELECTRONICS CO., LTD | | |
| MTL | SPEC | DISPOSAL |
| △5 | | UNIT MM |
| △4 | | SCALE 2 / 1 |
| △3 | | TITLE: DB-EC16 Series |
| △2 | DRAWN 谭超 | DESIGN 李弘 |
| △1 | | CHECK 张琪 |
| DEVISION | DATE | DESIGN |
| | | DWG NO.: F-EC16-05-28 |